

REV	DESCRIPTION	DRAWN	DATE

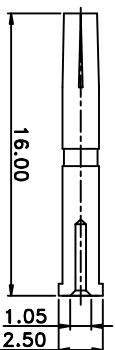

NO	Description	Qty	Material	Finish
9	NUT	1	BRASS	NICKEL
8	GASKET	1	RUBBER	ORANGE
7	WASHER	1	BRASS	NICKEL
6	FERRULE	1	DELIRIN	NONE
5	FERRULE	1	BRASS	NICKEL
4	DIELECTRIC	1	TEFLON	NONE
3	DIELECTRIC	1	TEFLON	NONE
2	PIN	1	BRASS	GOLD
1	BODY	1	BRASS	NICKEL

R&D

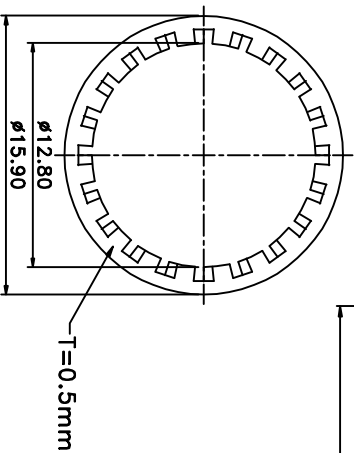
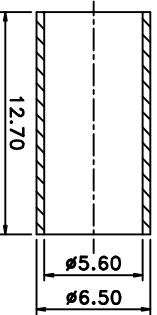
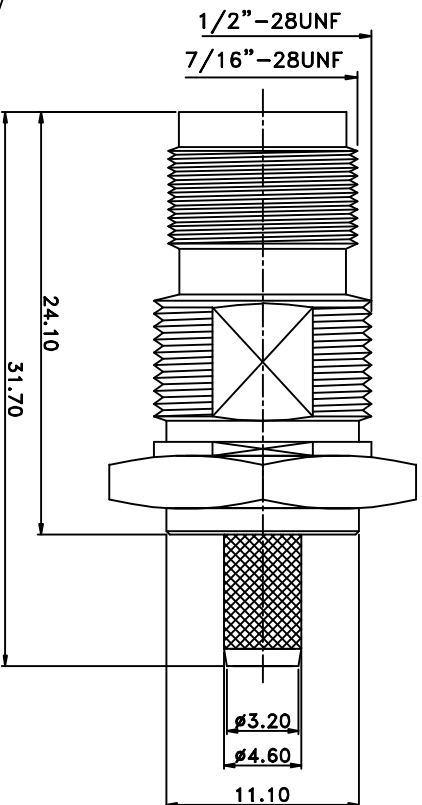
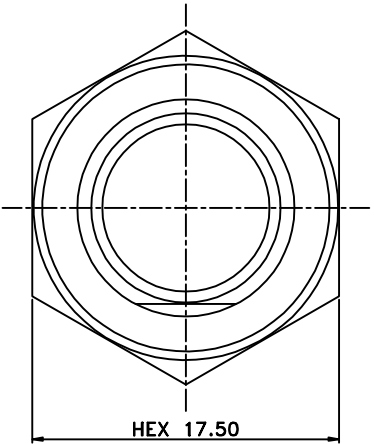
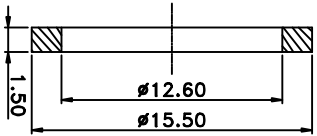
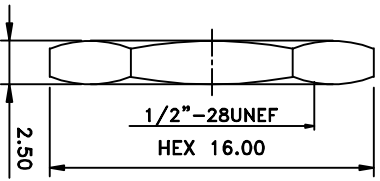
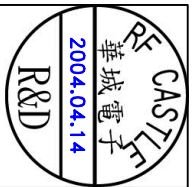

* MAJOR DIMENSION

UNLESS OTHERWISE NOTED TOLERANCES

0.5-6=±0.2
6-30=±0.4
30-120=±0.6
120-315=±1.0
ANGLES=±1°

SCALE 5/2 UNIT MM

APPROVED CASH

CHECKED LYDIA

DRAWN PEN

DRAWN PEN

DRAWN DATE 04/04/14



TITLE

SMA MALE TO SMA FEMALE RP

DRAWING NO.

SMA-1057-2-RP-TGG

REV

REV A